

## Recessed Skin Fittings (Thru Hulls)



Designed and made in New Zealand, TruDesign Skin Fittings (Thru Hulls) are precision moulded from glass-reinforced Nylon composite.

- Certified to ISO 9093-2 by the International Marine Certification Institute (IMCI, Belgium).
- Comply with ABYC H-27 standards when used in conjunction with the TruDesign ABYC collar.
- Certified by **Bureau Veritas** to ISO 9093-2.

TruDesign Skin Fittings (Thru Hulls) eliminate all corrosion and bonding problems associated with electrolysis giving peace of mind with respect to the safety of your vessel.

### Features:

- Low profile for less drag below the water line.
- Compatible with all hull types – Can be used on aluminium, steel, wood, composite & GRP hulls.
- Immune to corrosion & electrolysis – No corrosion breakages, increased safety.
- Chemical resistant – Unaffected by diesel, petrol, chemicals, and antifouling paints.
- U.V resistant – Will not degrade or discolour from the sun's ultraviolet rays.
- Paintable – Paintable with all types of antifoul including Coppercoat™
- Fits TruDesign Ball Valves and other parallel BSP or NPS threads – Universal compatibility to TRUDESIGN™ brand fittings and other marine hardware.
- Large operating range – Suitable for all marine conditions from -40°C to +110°C
- Meet ABYC H-27 Standard when installed in combination with TruDesign Ball Valves & Load Bearing Collars.

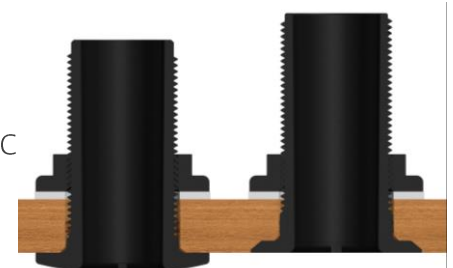

## MODELS

Part #	Description
90676	Skin Fitting Recessed 1/2" BSP Black
90677	Skin Fitting Recessed 3/4" BSP Black
90678	Skin Fitting Recessed 1" BSP Black
90679	Skin Fitting Recessed 1 1/4" BSP Black
90680	Skin Fitting Recessed 1 1/2" BSP Black

Part #	Description
90714	Skin Fitting Recessed 1/2" NPS Black
90715	Skin Fitting Recessed 3/4" NPS Black
90716	Skin Fitting Recessed 1" NPS Black
90717	Skin Fitting Recessed 1 1/4" NPS Black
90718	Skin Fitting Recessed 1 1/2" NPS Black

Part #	Description
90709	Skin Fitting Recessed 1/2" BSP White
90710	Skin Fitting Recessed 3/4" BSP White
90711	Skin Fitting Recessed 1" BSP White
90712	Skin Fitting Recessed 1 1/4" BSP White
90713	Skin Fitting Recessed 1 1/2" BSP White

Part #	Description
90732	Skin Fitting Recessed 1/2" NPS White
90733	Skin Fitting Recessed 3/4" NPS White
90734	Skin Fitting Recessed 1" NPS White
90735	Skin Fitting Recessed 1 1/4" NPS White
90736	Skin Fitting Recessed 1 1/2" NPS White

## DIMENSIONS & WEIGHTS

All dimensions in millimetres. All dimensions nominal. All weights in grams

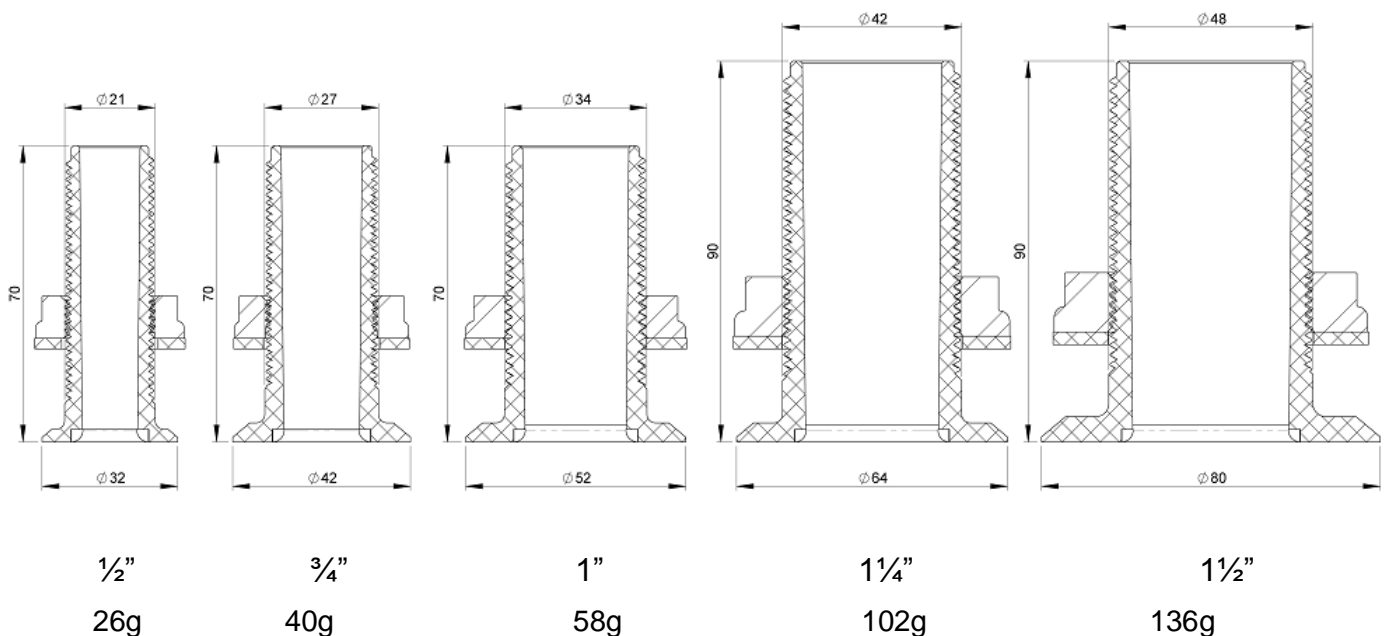

## Internal Hole Diameter and Hull Thickness:

Size	Minimum I.D.	Maximum Hull Thickness allowing 70% thread engagement into Ball Valve
½" BSP	12mm	36mm
¾" BSP	17mm	36mm
1" BSP	23mm	36mm
1¼" BSP	30mm	49mm
1½" BSP	36mm	49mm

Note; it is recommended for very thin hulls that a backing plate be added to make the “effective hull thickness” a minimum of 20mm.

## Standards & Approvals:

### ISO 9093-2 Standard

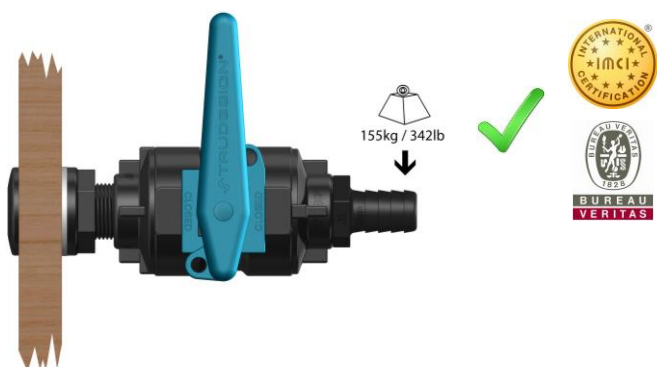

In accordance with ISO 9093-2 standards, Skin Fittings (Thru Hulls) are subjected to a 155kg (341.7lb) load, applied to the threaded section for a minimum of 30 seconds, without any damage occurring. TruDesign Skin Fittings (Thru Hulls) meet this standard.

Note: ½" size Skin Fitting (Thru Hulls) are not approved to ISO 9093-2 or ABYC unless used with an ABYC collar.

### ABYC H-27 Standard

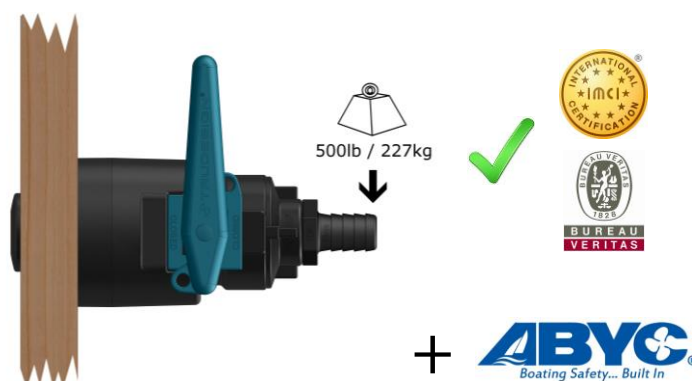

TruDesign Skin Fittings (Thru Hulls), when assembled together with TruDesign Ball Valves and Load Bearing Collars, comply with ABYC H-27 standards. This allows the entire assembly to withstand a 500lb (226.8kg) load applied to the inboard end of the assembly (i.e. from the Ball Valve’s Tail fitting) for a minimum of 30 seconds without any damage occurring.

## Installation: Location & Drilling

- Ensure there is sufficient room on the inside of the boat to allow the Ball Valve to be screwed on without hitting the bulkhead or other part of the hull and will not cause the valve handle to be knocked open or closed. Note; A “T” handle Ball Valve is available for smaller area locations
- Drill from the inside a pilot hole 3mm in diameter, then drill from the outside of the hull a recess that is 1mm larger in diameter than the flanged head of the chosen Skin Fitting. Only drill deep enough to allow the flange of the Skin Fitting to sit in the recess flush with the outside of the hull. A hole-saw can be used to cut the recess and a chisel used to remove the material.
- Making the skin fitting hole. Drill through the centre a hole that is 1mm larger in diameter than the outside diameter of the thread of the chosen Skin Fitting. A packer may be required to provide a stronger and flat surface for the nut and washer on the inside of the hull. For very thin hulls a backing plate needs to be added to make the “effective hull thickness” a minimum of 20mm.
- It is recommended to “dry fit” the Ball Valve Skin fitting assembly and then trim the skin fitting (with a hacksaw) to allow a 2mm to 5mm gap between Skin Fitting Nut and Ball Valve to minimise overhang.



- TruDesign Skin Fittings (Thru Hull) are suitable for installation in all types of hull construction; steel, aluminium, composite, fibreglass – cored and solid, wood, wooden sandwich and caulked solid wood hulls. Ensure fittings are always installed in the centre of individual planks

- For boat builders of GRP and vacuum moulded hulls a disposable mould plug is available that automatically “shapes” the hull to the recess of the skin fitting and provide a location centre hole – See separate information sheet. – GRP Mould Plugs



## Recommended Hull Adhesive Sealants & Glues.

First clean all surfaces to be bonded with a general purpose cleaner.

- 3M™ Marine Adhesive Sealant Fast Cure 5200. A one-part polyurethane adhesive/sealant. Starts to cure (tack-free) in approximately 2 hours, after which hoses can be attached. Full cure takes 24 hours – refer to manufacturer’s product literature.
- SIKAFLEX® 291i Marine Sealant. A one-part polyurethane adhesive/sealant. Starts to cure (tack-free) in approx. 2 hours, after which hoses can be attached. Full cure takes 24 hours – refer to manufacturer’s product literature.
- Bostik® 920 Marine Sealant. A one-part urethane adhesive/sealant. Starts to cure (tack-free) in approx. 2 hours, after which hoses can be attached. Full cure takes 1.5 – 3 days – refer to manufacturer’s product literature.
- West System® (or similar) two-pot epoxy that mixes to a paste. Tip – adding filler to the West System® will increase the viscosity and help minimise “running” of the epoxy. Visit <http://www.westsystem.com/ss/filler-selection-guide/> for more details.

## Fitting & Sealing

- Smear the adhesive or glue on the underside of the Skin Fitting (Thru Hull) flange and a small way up the thread, but no further than the thickness of the hull. It is important not to have any adhesive on the exposed thread area as this could prevent the Nut or Ball Valve from turning.
- Insert the Skin Fitting (Thru Hull) through the hull from the outside. Note The TruDesign Skin Fitting Installation Tool enables our skin fittings to be installed by one person saving time and money. See separate information sheet on our web site.
- If necessary, place two strips of masking tape over the flange and attach to the hull to temporarily hold in place. Go inside the hull to fit the Nut. Note it is good practice to have a backing plate to spread the load especially if there is excessive curvature in the hull or the hull is very thin.
- Hold the thread down near the washer and screw on the Nut. Once the nut is screwed down far enough that you can hold the fitting above the nut do so and continue to screw the nut down onto the washer ensuring it is only finger tight.
- On the outside of the hull clean off any excess adhesive. Tip – use an angled tool or putty knife to ‘blend’ adhesive around the Skin Fitting (Thru Hull) flange and the hull so it is easier to clean when sanding and antifouling in the future.
- After recommended curing times, tighten the Nut to about 15 ftlb. There is no need to over-tighten the Nut, especially if epoxy has been used, as the Skin Fitting (Thru Hull) is now an integral part of the hull.



*Epoxy or adhesive sealant area shown in blue*

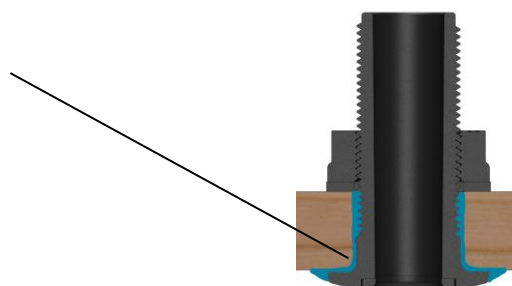

## Thread Sealing

- All the sealants mentioned above under “Hull Adhesives” can be used for thread sealing. These adhesive sealants allow the Ball valve to be “set in position” to suit handle operation with no risk of turning when in use. If in the unlikely event the Ball Valve has to be removed this will require significant force.
- 3M™ Marine Adhesive Sealant Fast Cure 4200 is approximately half the strength (once cured) of 3M 5200 which allows for eventual disassembly of the ball valve from skin fitting.
- LOCTITE® 5331 A one-part acetoxy silicone sealant. Starts to cure (tack-free) in approx. 10 minutes, after which hoses can be attached. Full cure is achieved within 12 hours (at min. 40% atmospheric humidity) – refer to product literature. Creates a permanent seal for threaded connections.
- PTFE (Teflon) Thread Tape is a traditional thread sealing method which provides a good seal when applied correctly. However, in some cases if the position or tightness of the Ball Valve is incorrect, it will need to be unscrewed and more tape applied, slowing the assembly process. Additionally, the fittings can sometimes be turned by hand after being installed.
- LOCTITE® 55 Pipe Sealing Cord is a coated multi-filament cord designed as a faster method than Teflon tape to seal threaded fittings. The main advantage is that a component, for example a Ball Valve, could be screwed down then screwed back a turn to suit positioning whilst still maintaining a tight seal. This eliminates the need to remove the entire Ball Valve and apply more tape as with traditional Teflon tape.

TruDesign Skin Fittings (Thru Hulls) are printed and marked with the following information;

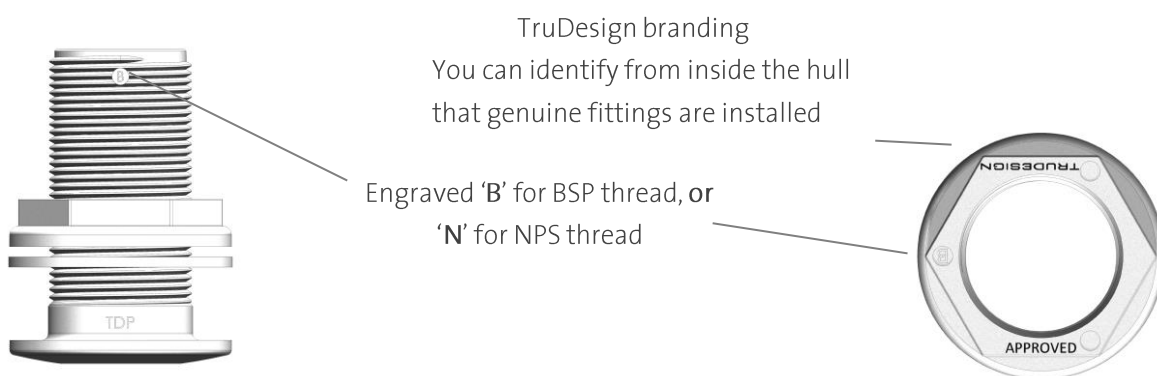

The information contained in this information sheet is for general information purposes only. The information is provided by TruDesign and while we endeavour to keep the information up to date and correct, we make no representations or warranties of any kind, express or implied, about the completeness, accuracy, reliability, suitability or availability. Any reliance you place on such information is therefore strictly at your own risk.